

## HS-700A-N Technical Data Sheet

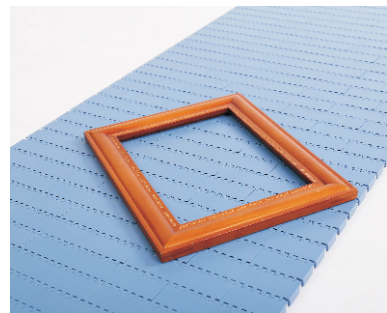
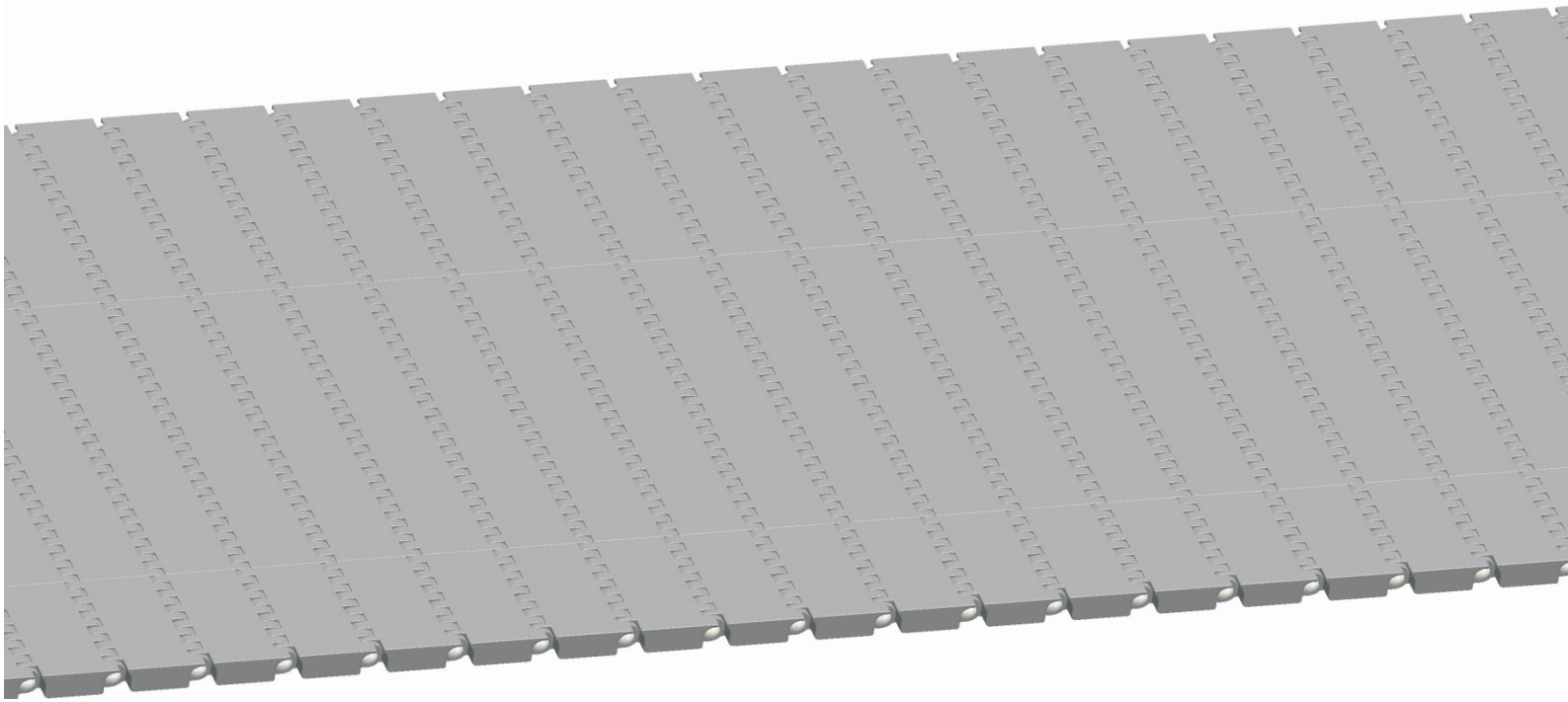

<p>Pitch: 27.2mm                  Minimum Width: 152mm                  Open Area: 0%                  Approved: FDA                  Rod: Ø 4.5mm                  Flight: Yes                  Side Guard: Yes                  Curve: No</p>	
---	--

## Data

Belt Material	Belt Strength			Temperature		Belt Weight (Kg/M <sup>2</sup> )
	Straight		Curve	°C (min.)	°C (max.)	
	Kg/M(BW)	N/M(BW)				
Polypropylene	1340	13400	--	1	100	4.9
Polyethylene	1060	10600	--	-60	60	5.7
Acetal	1880	18800	--	-40	80	6.8
Nylon	1610	16100	--	1	180	6.5

BW – Belt Width

## Color Table

Polypropylene					Polyethylene					Acetal					Nylon				
W	G	N	DB	B	W	G	N	DB	B	W	G	N	DB	B	W	G	N	DB	B
●	●						●			●	●			●		●			

W-White, G-Gray, N-Nature, DB-Dark brown, B-Blue (For more information of belt color, pls consult our sales team)

## Friction Table

Belt Material	Friction Wear strips & Products							
	UHMW	HDPE	Steel	Glass	SUS	Plastic	Cardboard	Aluminum
Polypropylene	0.32	0.24	0.15	0.09	0.13	0.08	0.15	0.25
Polyethylene	0.13	0.11	0.26	0.19	0.31	0.16	0.21	0.41
Acetal	0.11	0.09	0.27	0.16	0.26	0.15	0.19	0.28
Nylon	0.18	0.13	0.25	0.16	0.26	0.16	0.19	0.27

SUS – Stainless Steel

## Equivalent type with other Brand

Brand Name	Intralox	Habasit	UNI	Rexnord	MCC	ScanBelt
Series & Type	S900 Flat Top	--	--	--	--	--

The above content is only for reference.

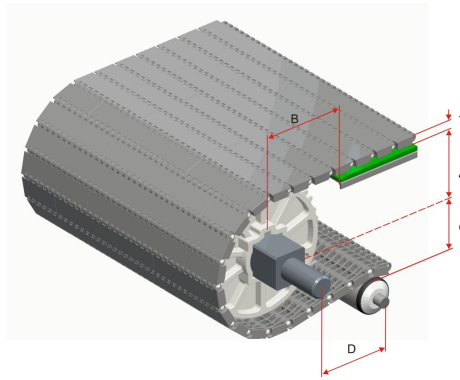

## Conveyor Frame Dimensions

Unit : mm

No. Teeth	A ( Min.)	B ( Min.)	C ( Max.)	D ( Min.)	T
6	21.25	36.15	20.35	200	9.8
9	35	49.9	34.1	200	
10	38.85	53.75	37.95	250	
12	47.85	62.75	46.95	250	
17	71.1	86	70.2	300	
18	74	88.9	73.1	300	
20 / 20-Split	82.6	97.5	81.7	300	
24	100	114.9	99.1	300	

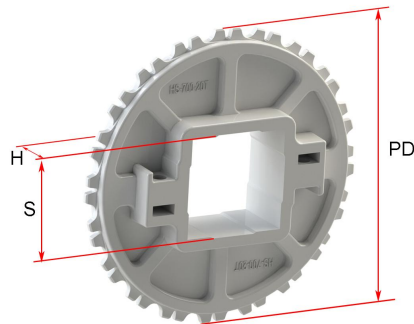
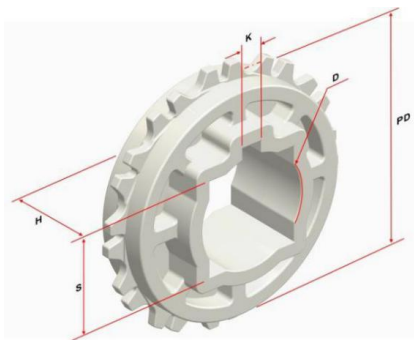

## Sprocket Dimensions

Unit: mm

No. Teeth	PD	OD	S	D	H	K
6	54.40	52.3	25.4	--	18.5	--
9	79.53	79.8	25.4/38.1/40	25.4	21.5	6.35X3.17
10	88.02	87.5	25.4/38.1/40	25.4/30	18.8	6.35X3.17
12	105.09	105.5	25.4/30/38.1/40	25.4/30/31.75/35/38.1/45/47/50	35	6.35X3.17
17	148.03	152	--	114	35	4.5X4.5
18	156.64	157.8	38.1/40/50/60/63.5	25.4/30/31.75/35/38.1/40/46/47	35	6.35X3.17
20	173.87	175	38.1/40/60	25.4/30/31.75/38.1	35	6.35X3.17
20-Split	173.87	175	60	31.75/30	40	6.35X3.17
24	208.39	209.8	38.1/40	25.4/30/38.1/45	35	8X8